

# FOLLOW DESK 299F



## DESCRIPTION / DESCRIZIONE

**en** Follow is height-adjustable table that effortlessly and noiselessly adjust to the user's posture and need. Single working desk with powder coated metal frame and chromed height excursion column, available in different sizes from 1200 to 1800 mm width. Height-adjustable metal handle. A table that can be placed and moved anywhere: it is not connected to any cable as it does not need any electricity supply.

**it** Follow è il tavolo regolabile in altezza che permette di trovare in modo facile, veloce e silenzioso la giusta posizione. Scrivania singola operativa con struttura in acciaio verniciato e colonna di escursione dell'altezza cromata, disponibile con piano in diverse dimensioni da 1200 a 1800 mm di larghezza. Maniglia di regolazione dell'altezza in metallo. Follow può essere disposto liberamente nella stanza non avendo bisogno di alcuna alimentazione elettrica.

FOLLOW DESK  
**sit-stand table**  
tavolo regolabile in altezza

### 299F Small

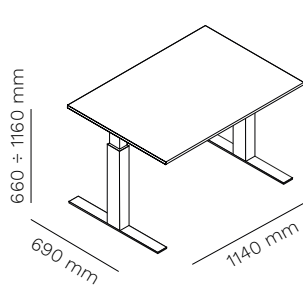

top  
1200 - 1400 x 700 - 800 mm

### 299F Large

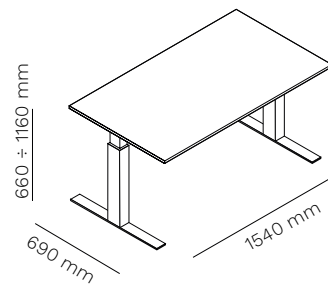

top  
1600 - 1800 x 700 - 800 mm



**Seal of Excellence from the European Union's 2020 Research and Innovation Programme.**

Sigillo d'Eccellenza dal Programma di Ricerca e Innovazione dell'Unione Europea Horizon 2020.



**patented system**  
sistema brevettato



**certified versions**  
versioni certificate  
**EN 527-1:2011**



**version with FSC® certified top**  
versione con piano certificato FSC®



**fast**  
veloce



**silent**  
silenzioso



**no electricity**  
no elettricità



**adjustable height**  
altezza regolabile

**version standard**  
versione standard



<b>2 LEGS</b> 2 GAMBE	<b>29 Kg</b>	<b>1 pc</b> 0,035 mc	<b>15 pcs /</b> 130 x 110 cm pallet
<b>1 BEAM</b> <b>1200 - 1400 mm</b> 1 TRAVERSA 1200 - 1400 mm	<b>6 kg</b>	<b>1 pc</b> 0,025 mc	<b>45 pcs /</b> 160 x 100 cm pallet
<b>1 BEAM</b> <b>1600 - 1800 mm</b> 1 TRAVERSA 1600 - 1800 mm			

**version with loading adjuster**  
versione con regolazione di portata



<b>2 LEGS</b> 2 GAMBE	<b>29 Kg</b>	<b>1 pc</b> 0,035 mc	<b>15 pcs /</b> 130 x 110 cm pallet
<b>1 BEAM</b> <b>1200 - 1400 mm</b> 1 TRAVERSA 1200 - 1400 mm	<b>9 kg</b>	<b>1 pc</b> 0,025 mc	<b>45 pcs /</b> 160 x 100 cm pallet
<b>1 BEAM</b> <b>1600 - 1800 mm</b> 1 TRAVERSA 1600 - 1800 mm			

**FOLLOW DESK**  
299F

**mara**<sup>®</sup>

**INCLUDED ACCESSORIES / ACCESSORI INCLUSI**

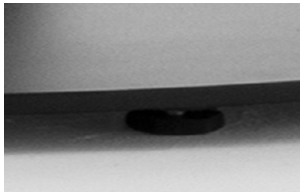

**foot levelers**  
piedini livellatori

**ACCESSORIES / ACCESSORI**

**299FTI**

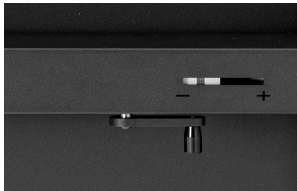

**beam with loading adjuster**  
traversa con regolazione di portata

**299FZ**



**counter balance kit**  
(2 zavorre 1,2 kg/cad.)  
counter balance kit  
(2 x 1,2 kg ballasts)

**511PLUS**



**top access with flip cover**  
passacavi con sportello

**511EPLUS**



**top access with multifunctional sockets**  
passacavi con prese multifunzione

**PASD60**



**multifunctional sockets**  
Ø 60 mm  
prese multifunzione  
Ø 60 mm

**PASD80**



**multifunctional sockets with wireless charging**  
Ø 80 mm  
prese multifunzione con ricarica wireless Ø 80 mm

**299FP**

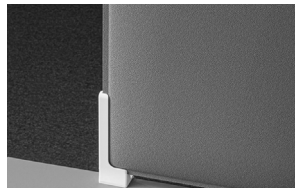

**sound-absorbing panel**  
pannello fonoassorbente

**215V**



**cable tray to fix under top**  
(3 kg)  
vasca porta cavi fissaggio sotto piano (3 kg)

**300**



**cpu holder**  
portaserver

**500DROLL**



**mobile storage system, on castors**  
cassettera mobile su ruote

**K075 \***



**Kit of 4 castors Ø 75 mm**  
Kit 4 ruote Ø 75 mm

**\* the table will be 75 mm higher**  
\* il tavolo si alzerà di 75 mm

# FOLLOW DESK 299F

# mara®

## FRAME / STRUTTURA

**powder coated steel**  
acciaio verniciato



**296**  
**textured**  
raggrinzato  
RAL 9010



**301**  
**textured**  
raggrinzato  
RAL 7044



**444**  
**textured**  
raggrinzato  
RAL 8004



**700**  
**textured**  
raggrinzato  
RAL 7000



**203**  
**textured**  
raggrinzato  
RAL 6003



**111**  
**textured**  
raggrinzato  
RAL 5011



**333**  
**textured**  
raggrinzato  
RAL 3003



**131**  
**textured**  
raggrinzato  
RAL 9006



**148**  
**textured**  
raggrinzato  
RAL 7016



**120**  
**textured**  
raggrinzato  
RAL 9005

**height excursion column**  
colonna di escursione dell'altezza



**eco chrome**  
cromo ecologico

## TOP / PIANO

**standard FENIX tops**  
piani standard in FENIX



**0754**  
Blu  
Fes



**0791**  
Giallo  
Evora



**0751**  
Rosso  
Jaipur



**0750**  
Verde  
Comodoro



**0032**  
Bianco  
Kos



**0720**  
Nero  
Ingo

**STANDARDS AND CERTIFICATES / NORME E CERTIFICATI**  
Resistance to scratching EN 438-2:2019 - CL.25 Class  $\geq 4$  •  
Resistance to staining EN 438-2:2019 - CL.26 Group 1 e 2: Class 5 Group 3: Class  $\geq 4$  • Resistance to dry heat (160°C/20') - EN 438-2:2019 - CL.16 Class 5 • Lightfastness (xenon arc) EN 438-2:2019 - CL.27 Grayscale classification  $\geq 4$  • Resistance to steam

EN 438-2:2019 - CL.14 Class 5 • Specular surface reflection ISO 2813 8 ÷ 16 a 85° Unità Gloss • Resistance to surface wear EN 438-2:2019 - CL.10 Rotation value IP  $\geq 200$  • Resistance to damp heat (100°C/20') - EN 438-2:2019 - CL.18 Class 5

**TOP / PIANO**

**standard colour and material effect laminate tops**

piani standard in laminato colore ed effetto materico



**white**  
bianco



**magnolia**



**light grey**  
grigio  
chiaro



**anthracite**  
antracite



**black**  
nero



**white marble**  
marmo  
bianco



**grey marble**  
marmo  
grigio



**graphite marble**  
marmo  
grafite



**black marble**  
marmo  
nero



**whitened oak**  
rovere  
sbiancato



**natural oak**  
rovere  
naturale



**grey oak**  
rovere  
grigio



**black oak**  
rovere  
nero



**walnut**  
noce



**rose**  
rose



**yellow**  
giallo



**light blue**  
azzurro



**green**  
verde

**STANDARDS AND CERTIFICATES / NORME E CERTIFICATI**

Dimensional tolerance related to the thickness  $\pm 0,3$  mm • Dimensional tolerance related to the sizes  $\pm 5,0$  mm • Resistance to scratching EN 438-2:2016 Class 3 • Resistance to staining EN 438-2:2016 Group 1 e 2: Class  $\geq 4$  Group 3: Class  $\geq 4$  • Resistance to dry heat (160°C/20') - EN 438-2 Class 4 • Lightfastness (xenon arc) EN 438-2 Grayscale classification  $\geq 4$

• Resistance to steam EN 438-2 Class 4 • Resistance to surface wear EN 438-2 Rotation value IP  $\geq 150$  • Resistance to damp heat (100°C/20') - EN 438-2 Class 4

**standard colour and wood melamine tops**

piani standard in nobilitato colore e legno



**white**  
bianco



**magnolia**



**light grey**  
grigio  
chiaro



**anthracite**  
antracite



**black**  
nero



**whitened oak**  
rovere  
sbiancato



**natural oak**  
rovere  
naturale



**grey oak**  
rovere  
grigio



**black oak**  
rovere  
nero



**walnut**  
noce

**STANDARDS AND CERTIFICATES / NORME E CERTIFICATI**

Dimensional tolerance related to the sizes  $\pm 5,0$  mm • Resistance to scratching 1,5 N • Resistance to cigarette burning 3 grade - moderate change in gloss level and/or moderate brown spots • Resistance to surface wear Rotation value IP  $< 50$  Rotation value WR  $< 150$  • Risk of breakage  $\geq 3$  group • Dimensional tolerance related to the thickness  $15 \leq X \leq 20$  mm :  $\pm 0,3$  mm  $X < 20$  mm :  $\pm 0,5$  mm • Resistance to staining  $\geq 3$  group

• Resistance to steam 4 grade - moderate change in gloss level and/or color • Surface imperfections Prolate imperfections:  $< 20$  mm/m Punctiform imperfections:  $< 2$  mm<sup>2</sup>/m<sup>2</sup> • Lightfastness (xenon arc)  $> 6$  group

## TECHNICAL SPECIFICATION

### 299F Small

**mara**<sup>®</sup>

> Follow Desk Small has a height range of 500 mm.

> Excluding the table tops it has a minimum height of 660 mm and a maximum of 1160 mm. Certified UNI EN 527 with a 20 mm thick top.

> Follow Desk Small can be used with table tops from 1200 mm to 1400 mm wide and from 700 mm to 800 mm deep.

> The table frame (1140x690 mm) is designed for optimal operation in a range of weights (top weight + accessories weight) between 23 and 31 kg.

> Depending on the intended use of the table, carefully evaluate the weight of the table top to be assembled:

E.g. when using a 14 kg table top, at least 9 kg accessories weight (computer, telephone, etc.) are required to reach the optimal operating range, while it is not recommended to load more than 17 kg.

> If a lighter table top is to be installed or if the table is to work without additional weight, fitting the “counter-balance kit” will be able to reduce from 1,2 to 9,6 kg the upwards thrust allowing the optimal operating range of top. For further information please contact our Customer Service.

> If a heavier top is to be mounted or additional loading is planned (computer, telephone, etc.), the upward thrust can be increased from 1,2 to 7,2 kg by removing six pre-mounted ballasts in the beam. For further information please contact our Customer Service.

> The beam with loading adjuster (optional), offers the possibility of further increasing the upward thrust from 0 to 10 kg.

Desk Small	min	max
height range (mm)	500	
frame height (mm)	660	1160
table top width (mm)	1200	1400
table top depth (mm)	700	800
table top weight + accessories recommended weight (kg)	23	31 / 41 *
counter-balance pre-assembled (kg)	-1,2	-7,2
counter-balance kit ** (kg)	1,2	9,6

\* maximum weight for the version with loading adjuster

\*\* optional

TOP WEIGHTS					TOP + CLIENT LOADING RECOMMENDED WEIGHT (kg)	
	Depth	Width			MIN	MAX
SINGLE TOP		1200 mm	1300 mm	1400 mm		
MELAMINE TOP 18/19 mm	700 mm	11 kg **	12 kg **	12 kg **	23	31 / 41 *
	800 mm	12 kg **	13 kg **	14 kg		
MELAMINE TOP 25 mm	700 mm	14 kg	15 kg	16 kg		
	800 mm	15 kg	17 kg	18 kg		
LAMINATE AND FENIX TOP 20 mm	700 mm	13 kg **	14 kg	15 kg		
	800 mm	15 kg	16 kg	17 kg		
LAMINATE AND FENIX TOP 27 mm	700 mm	17 kg	19 kg	20 kg		
	800 mm	20 kg	21 kg	23 kg		

\*\* ATTENTION TO WEIGHT CALCULATIONS

\* maximum weight for the version with loading adjuster

#### PLEASE NOTE: OBSERVE THE WEIGHTS INDICATED

> A load, on the frame, exceeding the maximum weight indicated (top weight + accessories weight), causes a rapid lowering of the table top when unlocked.

> A load, on the frame, below the minimum weight indicated (top weight + accessories weight), causes an excessive upward thrust of the table when unlocked.

## TECHNICAL SPECIFICATION

### 299F Large

**mara**<sup>®</sup>

> Follow Desk Large has a height range of 500 mm.

> Excluding the table tops it has a minimum height of 660 mm and a maximum of 1160 mm. Certified UNI EN 527 with a 20 mm thick top.

> Follow Desk Large can be used with table tops from 1600 mm to 1800 mm wide and from 700 mm to 800 mm deep.

> The table frame (1540x690 mm) is designed for optimal operation in a range of weights (top weight + accessories weights) between 30 and 38 kg.

> Depending on the intended use of the table, carefully evaluate the weight of the table top to be assembled:

E.g. when using a 18 kg table top, at least 12 kg accessories weight (computer, telephone, etc.) are required to reach the optimal operating range, while it is not recommended to load more than 20 kg.

> If a lighter table top is to be installed or if the table is to work without additional weight, fitting the “counter-balance kit” will be able to reduce from 1,2 to 9,6 kg the upwards thrust allowing the optimal operating range of top. For further information please contact our Customer Service.

> The beam with loading adjuster (optional), offers the possibility of further increasing the upward thrust from 0 to 10 kg.

Desk Large	min	max
height range (mm)	500	
frame height (mm)	660	1160
table top width (mm)	1600	1800
table top depth (mm)	700	800
table top weight + accessories recommended weight (kg)	30	38 / 48 *
counter-balance kit ** (kg)	1,2	9,6

\* maximum weight for the version with loading adjuster

\*\* optional

TOP WEIGHTS					TOP + CLIENT LOADING RECOMMENDED WEIGHT (kg)	
	Depth	Width			MIN	MAX
SINGLE TOP		1600 mm	1700 mm	1800 mm		
MELAMINE TOP 18/19 mm	700 mm	14 kg **	15 kg **	16 kg	30	38 / 48 *
	800 mm	16 kg	17 kg	18 kg		
MELAMINE TOP 25 mm	700 mm	18 kg	19 kg	20 kg		
	800 mm	21 kg	22 kg	23 kg		
LAMINATE AND FENIX TOP 20 mm	700 mm	17 kg	18 kg	19 kg		
	800 mm	20 kg	21 kg	22 kg		
LAMINATE TOP 27 mm	700 mm	23 kg	24 kg	26 kg		
	800 mm	26 kg	28 kg	29 kg		

\*\* ATTENTION TO WEIGHT CALCULATIONS

\* maximum weight for the version with loading adjuster

#### PLEASE NOTE: OBSERVE THE WEIGHTS INDICATED

> A load, on the frame, exceeding the maximum weight indicated (top weight + accessories weight), causes a rapid lowering of the table top when unlocked.

> A load, on the frame, below the minimum weight indicated (top weight + accessories weight), causes an excessive upward thrust of the table when unlocked.

## INSTRUCTIONS FOR CORRECT USE

### FIRST USE:

A. Remove the safety-spacer from the adjustment handle (8a).

### ONLY IF NECESSARY:

A. Unscrew the nut (8b) and adjust the handle cable (8c): a clockwise rotation will loosen it, while a counter clockwise rotation will tighten it out. The adjustment is correct when the handle is neither loose nor hard.

B. Secure the nut (8b) after adjusting the cable tension of the handle (8c).

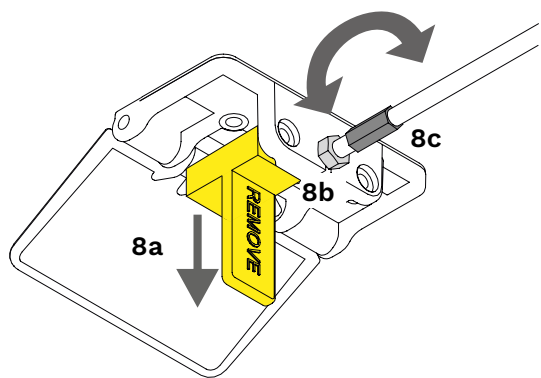

### DAILY USE:

1. Place one hand on the adjustment handle and the other hand on the same side of the table top, and operate the movement (fig. 1).
2. Using both hands, lift or lower the top to the desired height.
3. The table is easily adjustable.  
In case of difficult use, adjust the handles cable (see “only if necessary”).
4. Once the desired height has been reached, stop the movement and release the handle.  
The table will automatically lock in the desired position.

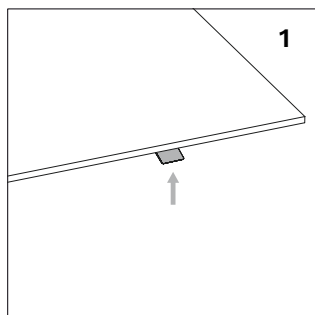

### ATTENTION

Any part of all components already assembled and supplied by the company cannot be disassembled unless this is done by Mara personnel. The assembly and disassembly of this table must be carried out by skilled operator following the instructions carefully.

## SPECIFICHE TECNICHE

### 299F Small

**mara**<sup>®</sup>

> Follow Desk Small ha un'escursione in altezza di 500 mm.

> Escluso il piano ha un'altezza minima di 660 mm e una massima di 1160 mm. Certificato UNI EN 527 con un piano spessore 20 mm.

> Follow Desk Small può montare piani da 1200 mm a 1400 mm di larghezza e da 700 mm a 800 mm di profondità.

> Il telaio del tavolo (1140x690 mm) è progettato per un funzionamento ottimale in un intervallo di pesi (peso piano + peso accessori) compresi tra i 23 e i 31 Kg.

> In base all'utilizzo previsto del tavolo, valutare attentamente il peso del piano da montare:

Es. in caso di utilizzo di un piano di 14 Kg, sono necessari almeno 9 Kg di peso accessori (computer, telefono, ecc.) per raggiungere l'intervallo di funzionamento ottimale, mentre è sconsigliato caricare più di 17 kg.

> Se è previsto l'utilizzo di un piano più leggero o non è previsto di caricare il piano di lavoro, il montaggio dell'accessorio "counter-balance kit" può ridurre da 1,2 a 9,6 kg la spinta verso l'alto, permettendo di raggiungere l'intervallo di funzionamento ottimale.

Per maggiori informazioni contattare il Servizio Clienti.

> Se è previsto il montaggio di un piano più pesante o è previsto di caricare ulteriormente il piano di lavoro (computer, telefono, ecc.), è possibile aumentare da 1,2 a 7,2 kg la spinta verso l'alto rimuovendo sei zavorre premontate nella traversa.

Per maggiori informazioni contattare il Servizio Clienti.

> La trave con regolazione di portata (opzionale), offre la possibilità di aumentare ulteriormente, la spinta verso l'alto da 0 a 10 kg.

Desk Small	min	max
escursione altezza (mm)	500	
altezza telaio (mm)	660	1160
larghezza piano (mm)	1200	1400
dimensioni piano (mm)	700	800
peso piano + peso accessori (kg) consigliato	23	31 / 41*
counter-balance pre-montato (kg)	-1,2	-7,2
counter-balance kit ** (kg)	1,2	9,6

\* peso massimo versione con regolazione di portata

\*\* opzionale

					PIANO + CARICO CLIENTE PESO CONSIGLIATO	
PESI PIANI	Profondità	Lunghezza			MIN	MAX
PIANO SINGOLO		1200 mm	1300 mm	1400 mm		
PIANO IN NOBILITATO SP 18/19 mm	700 mm	11 kg **	12 kg **	12 kg **	23	31 / 41 *
	800 mm	12 kg **	13 kg **	14 kg		
PIANO IN NOBILITATO SP 25 mm	700 mm	14 kg	15 kg	16 kg		
	800 mm	15 kg	17 kg	18 kg		
PIANO IN LAMINATO E FENIX SP 20 mm	700 mm	13 kg **	14 kg	15 kg		
	800 mm	15 kg	16 kg	17 kg		
PIANO IN LAMINATO E FENIX SP 27 mm	700 mm	17 kg	19 kg	20 kg		
	800 mm	20 kg	21 kg	23 kg		

\*\* ATTENZIONE AL CALCOLO DEI PESI

\* Peso massimo versione con regolazione di portata

### ATTENZIONE: ATTENERSI AI PESI INDICATI

> Un carico sopra il telaio superiore al peso massimo indicato (peso piano + peso accessori) causa un veloce abbassamento del piano al momento dello sblocco.

> Un carico sopra il telaio inferiore al peso minimo indicato (peso piano + peso accessori) causa un veloce innalzamento del piano al momento dello sblocco.



## SPECIFICHE TECNICHE

### 299F Large

**mara**<sup>®</sup>

> Follow Desk Large ha un'escursione in altezza di 500 mm.

> Escluso il piano ha un'altezza minima di 660 mm e una massima di 1160 mm. Certificato UNI EN 527 con un piano spessore 20 mm.

> Follow Desk Large può montare piani da 1600 mm a 1800 mm di larghezza e da 700 mm a 800 mm di profondità.

> Il telaio del tavolo (1540x690 mm) è progettato per un funzionamento ottimale in un intervallo di pesi (peso piano + pesi accessori) compresi tra i 30 e i 38 Kg.

> In base all'utilizzo previsto del tavolo, valutare attentamente il peso del piano da montare:

Es. in caso di utilizzo di un piano di 18 Kg, sono necessari almeno 12 Kg di pesi accessori (computer, telefono, ecc.) per raggiungere l'intervallo di funzionamento ottimale, mentre è sconsigliato caricare più di 20 kg.

> Se è previsto l'utilizzo di un piano più leggero o non è previsto di caricare il piano di lavoro, il montaggio dell'accessorio "counter-balance kit" può ridurre da 1,2 a 9,6 kg la spinta verso l'alto, permettendo di raggiungere l'intervallo di funzionamento ottimale. Per maggiori informazioni contattare il Servizio Clienti.

> La trave con regolazione di portata (opzionale), offre la possibilità di aumentare ulteriormente, la spinta verso l'alto da 0 a 10 kg.

Desk Large	min	max
escursione altezza (mm)	500	
altezza telaio (mm)	660	1160
larghezza piano (mm)	1600	1800
dimensioni piano (mm)	700	800
peso piano + peso accessori (kg) consigliato	30	38 / 48 *
counter-balance kit ** (kg)	1,2	9,6

\* peso massimo versione con regolazione di portata

\*\* opzionale

PESI PIANI					PIANO + CARICO CLIENTE PESO CONSIGLIATO	
	Profondità	Lunghezza			MIN	MAX
PIANO SINGOLO		1600 mm	1700 mm	1800 mm		
PIANO IN NOBILITATO SP 18/19 mm	700 mm	14 kg **	15 kg **	16 ** kg	30	38 / 48 *
	800 mm	16 kg	17 kg	18 kg		
PIANO IN NOBILITATO SP 25 mm	700 mm	18 kg	19 kg	20 kg		
	800 mm	21 kg	22 kg	23 kg		
PIANO IN LAMINATO E FENIX SP 20 mm	700 mm	17 kg	18 kg	19 kg		
	800 mm	20 kg	21 kg	22 kg		
PIANO IN LAMINATO SP 27 mm	700 mm	23 kg	24 kg	26 kg		
	800 mm	26 kg	28 kg	29 kg		

\*\* ATTENZIONE AL CALCOLO DEI PESI

\* peso massimo versione con regolazione di portata

#### ATTENZIONE: ATTENERSI AI PESI INDICATI

> Un carico sopra il telaio superiore al peso massimo indicato (peso piano + peso accessori) causa un veloce abbassamento del piano al momento dello sblocco.

> Un carico sopra il telaio inferiore al peso minimo indicato (peso piano + peso accessori) causa un veloce innalzamento del piano al momento dello sblocco.

## ISTRUZIONI D'USO

### AL PRIMO UTILIZZO:

A. Rimuovere il distanziale di sicurezza inserito nella maniglia di regolazione (8a).

### SOLO SE NECESSARIO:

A. Svitare il dado (8b) e regolare il cavo della maniglia (8c): una rotazione oraria lo allenterà mentre una rotazione antioraria lo tenderà. La regolazione è corretta quando la maniglia non risulta nè libera ne troppo dura.

B. Fissare il dado (8b) una volta regolata la tensione del cavo (8c).

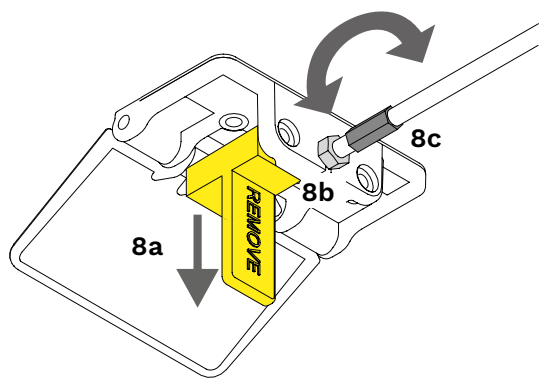

### USO QUOTIDIANO:

1. Posizionare la mano d'utilizzo sulla maniglia di regolazione e l'altra mano sullo stesso lato del piano e azionare il movimento (fig. 1).
2. Utilizzando entrambe le mani, sollevare o abbassare il piano all'altezza desiderata.
3. Il tavolo si regola facilmente.  
In caso di difficoltà nell'utilizzo, migliorare la regolazione del cavo della maniglia (vedi "solo se necessario").
4. Raggiunta l'altezza desiderata fermare il movimento e rilasciare la maniglia di regolazione.  
Il tavolo si bloccherà automaticamente nella posizione desiderata.

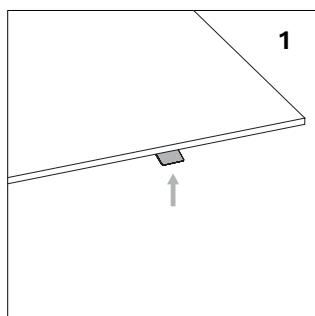

### ATTENZIONE

Ogni componente fornito già montato dall'azienda non può essere smontato in nessuna sua parte se non da personale Mara. Montaggio e smontaggio di questo tavolo deve essere effettuato da personale esperto seguendo attentamente le istruzioni.

**ACOUSTIC PANEL**  
PANNELLO FONOASSORBENTE



299FP

**DESCRIPTION / DESCRIZIONE**

**en** The sound-absorbing panel made with Snowsound technology is an excellent solution for dividing worktops by creating a visual barrier and optimising acoustic comfort. Application to the surface using special clamps. The panel has an Italian Class1 fire reaction and Euroclass B-s2, d0. The panel is 100% recyclable and has no detectable formaldehyde content according to UNI EN 717-2. The panel has been tested in reverberation chamber according to UNI EN ISO 354 and obtained "Acoustic Absorption Class A", in accordance with UNI EN ISO 11654.

**it** Il pannello fonoassorbente realizzato con la tecnologia Snowsound è un'ottima soluzione per suddividere i piani di lavoro creando una barriera visiva ed ottimizzando il comfort acustico. Applicazione al piano mediante appositi morsetti. Il pannello ha Classe1 Italia di reazione al Fuoco ed Euroclass B-s2, d0. Il pannello è riciclabile al 100% e ha un contenuto di formaldeide non rilevabile secondo la norma UNI EN 717-2. Il pannello è stato testato in camera riverberante secondo la norma UNI EN ISO 354 ed ha "Classe di Assorbimento Acustico A", in accordo con la norma UNI EN ISO 11654.

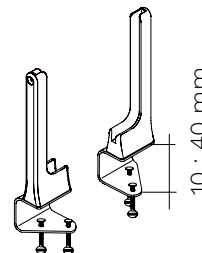
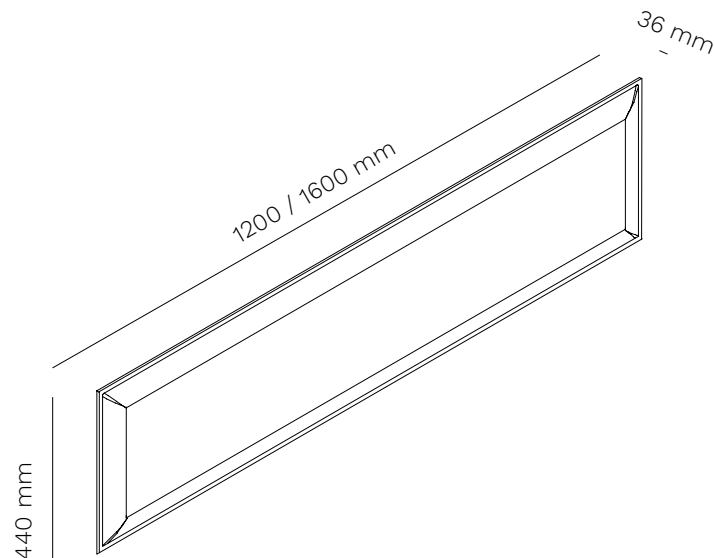

**en** Pair of brackets with clamp in powder-coated steel and zamac for connection to the desk top.

**it** Coppia attacchi in zama con morsetto in acciaio verniciati con polveri epossidiche per fissaggio al piano della scrivania.



1200 x 440 mm  
1,6 kg



1600 x 440 mm  
2,6 kg



**kit 2 brackets**  
kit 2 attacchi  
1,3 kg

**fire-retardant fabric**  
tessuto ignifugo



8004



8007



2005



8033



3008



7004



6071



4027

CLEANING AND MAINTENANCE / PULIZIA E MANUTENZIONE

STEEL / ACCIAIO

**en** Our types of metals include: chromed metals and painted metals. Do not use acid or alkaline based cleaning products. Do not use detergents, steel wool, dishwashing detergents or the like. Sharp or pointed objects may damage the surface. Any hot or wet object may cause surface damage. Clean the surface regularly with a soft cloth to remove dust. To remove light dirt, use a soft cloth and a neutral household cleaner.

**it** Le nostre tipologie di metallo comprendono: metalli cromati e metalli verniciati. Non utilizzare prodotti per la pulizia a base acida o alcalina. Non utilizzare detergenti, lana di acciaio, detersivi per stoviglie o simili. Oggetti appuntiti o taglienti possono danneggiare la superficie. Qualsiasi oggetto caldo o bagnato potrebbe provocare danni alla superficie. Pulire la superficie regolarmente con un panno soffice per rimuovere la polvere. Per rimuovere lo sporco leggero utilizzare un panno soffice e un prodotto per le pulizie di casa neutro.

CHROMED STEEL AND ALUMINIUM POLISHED / ACCIAIO CROMATO E ALLUMINIO LUCIDO

**en** Do not use acid or alkaline based cleaning products. Do not use detergents, steel wool, dishwashing detergents or the like. Sharp or pointed objects may damage the surface. Any hot or wet object may cause surface damage. Clean the surface regularly with a soft cloth to remove dust. To remove light dirt, use a soft cloth and a neutral household cleaner

**it** Non utilizzare prodotti per la pulizia a base acida o alcalina. Non utilizzare detergenti, lana di acciaio, detersivi per stoviglie o simili. Oggetti appuntiti o taglienti possono danneggiare la superficie. Qualsiasi oggetto caldo o bagnato potrebbe provocare danni alla superficie. Pulire la superficie regolarmente con un panno soffice per rimuovere la polvere. Per rimuovere lo sporco leggero utilizzare un panno soffice e un prodotto per le pulizie di casa neutro.

LAMINATE AND MELAMINE / LAMINATI E NOBILITATI

**en** Laminates and melamine products guarantee high performance in terms of resistance to scratches, shocks and abrasions. Keep furniture away from direct sunlight; furniture in direct sunlight may tend to discolour over time. Do not use acid or alkaline based cleaning products. Sharp or pointed objects can damage the surface. Laminate and melamine furniture can be cleaned using a mixture of liquid soap and hot water. Rinse with cold water and dry with a paper towel or damp cloth.

**it** Laminati e nobilitati garantiscono alte prestazioni di resistenza ai graffi, agli urti e alle abrasioni. Mantenere i mobili lontani dalla luce diretta del sole; i mobili che si trovano alla luce diretta del sole potrebbero tendere a scolorire nel tempo. Non utilizzare prodotti per la pulizia a base acida o alcalina. Oggetti appuntiti o taglienti possono danneggiare la superficie. E' possibile effettuare la pulizia dei mobili in laminato e nobilitato usando una miscela di sapone liquido e acqua calda. Sciacquare con acqua fredda e asciugare con un tovagliolo di carta o un panno umido.

STANDARD FENIX TOPS / PIANI STANDARD IN FENIX

**en** Cleaning FENIX means cleaning its structure. You can do this with warm water. As FENIX is a strong material, you can also use any household cleaner – even solvents like acetone \* if needed. However, to avoid damaging the structure, don't scrub it with abrasive cream, a scouring pad or a hard brush; in the long-term, this might lead to a glossy spot on your matt surface. Instead, you can use a melamine sponge – also known as a magic sponge. As a final step, to avoid anything staying behind in the structure – whether that's dirt or residue from your cleaner – always rinse afterward with warm water and wipe dry with a clean cloth.

\* always follow safety instructions

**it** Pulire FENIX significa pulirne la struttura. Si può farlo, usando acqua tiepida. Poiché FENIX è un materiale resistente, si può utilizzare qualsiasi detergente per la casa, se necessario anche un solvente come l'acetone \*. Tuttavia, per evitare di danneggiare la struttura, è consigliabile evitare di strofinarla usando una crema abrasiva, una spugna abrasiva o una spazzola con setole dure; nel tempo, ciò potrebbe portare alla formazione di un'area lucida sulla superficie opaca. Si può piuttosto utilizzare una spugna in melamina, nota anche come spugna magica. Come ultimo passaggio, per evitare la formazione di depositi nella struttura, che si tratti di sporco o residui del detergente, risciacquare sempre con acqua tiepida e asciugare con un panno pulito.

\* seguire sempre le istruzioni di sicurezza.

**BEAM WITH LOADING ADJUSTER**  
TRAVERSA CON REGOLAZIONE DI PORTATA

**mara**<sup>®</sup>

299FTI

**INSTRUCTIONS FOR PROPER USE**

The beam with loading adjuster offers the possibility of further increasing the thrust upward from 0 to 10 kg.

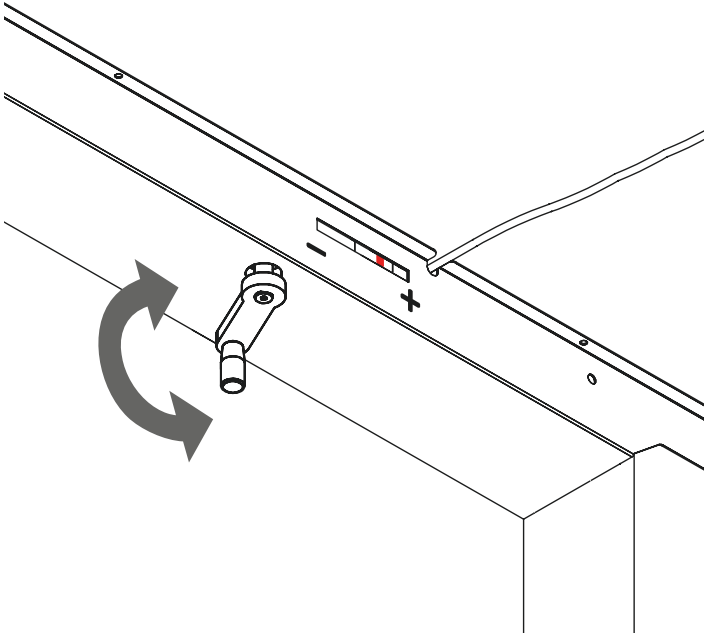

**DAILY USE:**

1. Place everything you need on the desk.
2. if the table tends to descend while using the the handle (fig.1), turn the lever counter-clockwise to increase the thrust upward. (the red marker will move towards the '+' sign).
3. if the table tends to rise while using the the handle (fig.1), turn the lever clockwise to decrease the thrust upward. (the red marker will move towards the '-' sign).

**fig. 1**

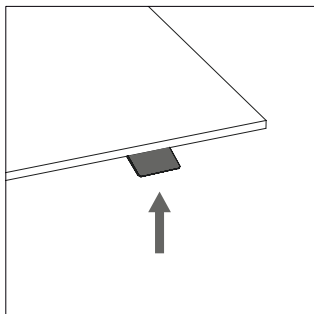

**ATTENTION**

Any part of all preassembled components, supplied by the company, cannot be disassembled unless this is done by Mara staff. The assembling and disassembling of this table must be carried out by skilled fitters following the instructions carefully.

**BEAM WITH LOADING ADJUSTER**  
TRAVERSA CON REGOLAZIONE DI PORTATA

**mara**<sup>®</sup>

299FTI

**ISTRUZIONI D'USO**

La trave con regolazione di portata offre la possibilità di aumentare ulteriormente la spinta verso l'alto da 0 a 10 kg.

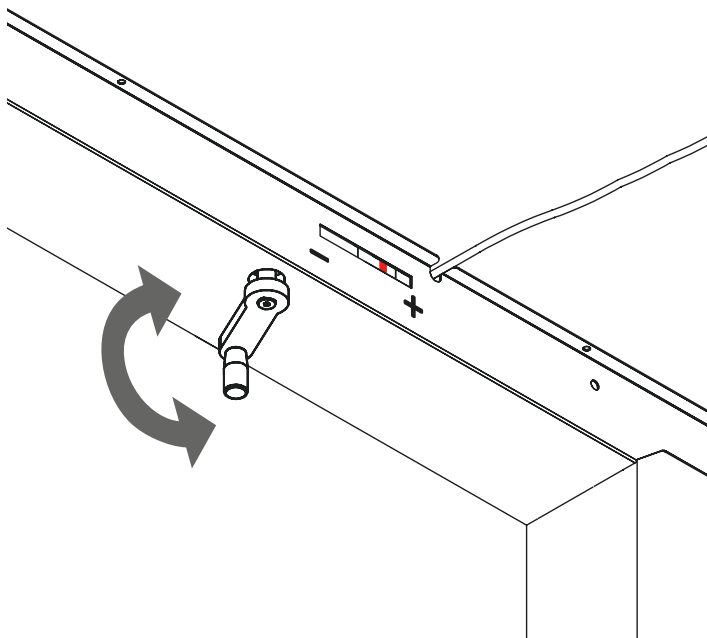

**USO QUOTIDIANO:**

1. Posizionare tutto il necessario sulla scrivania.
2. se il tavolo tende a scendere quando azionate la maniglia (fig.1), girare la leva in senso anti-orario per aumentare la spinta verso l'alto. (l'indicatore rosso si sposterà verso il segno "+").
3. se il tavolo tende a salire quando azionate la maniglia (fig.1), girare la leva in senso orario per diminuire la spinta verso l'alto. (l'indicatore rosso si sposterà verso il segno "-").

**fig. 1**

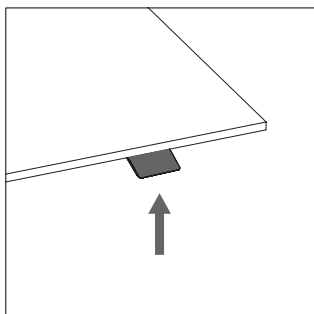

**ATTENZIONE**

Ogni componente fornito già montato dall'azienda non può essere smontato in nessuna sua parte se non da personale Mara. Montaggio e smontaggio di questo tavolo deve essere effettuato da personale esperto seguendo attentamente le istruzioni.

## TOP ACCESS

PASSACAVI

511PLUS

# mara®

### DESCRIPTION / DESCRIZIONE

**en Aluminium top access with flap. Black brush.**

**it Passacavi in alluminio con spazzola nera.**



1

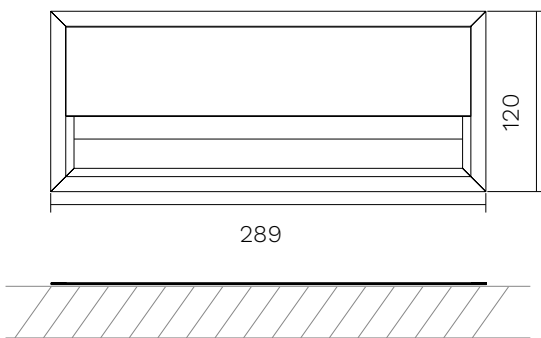

**All measurements are indicated in mm**  
Tutte le misure sono indicate in mm

### Surface cut-out area

Area di taglio della superficie

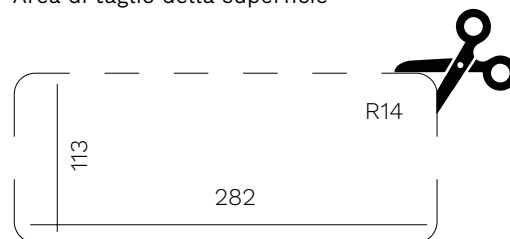

### COLOURS AVAILABLE / COLORI DISPONIBILI



**aluminium**  
alluminio



**black**  
nero



**TOP ACCESS WITH INTEGRATED POWER UNIT**  
**PASSACAVI CON MULTIPRESA INTEGRATA**

**mara**<sup>®</sup>

511EPLUS

**DESCRIPTION / DESCRIZIONE**

**en** Top access with integrated power unit for table tops max 30 mm thick, available in aluminium or black colour, 289x120 mm with 2 mt. power cable + 2 DE sockets + 2 USB 5V/2, 4A + 2 RJ45 sockets.

**it** Passacavo con multipresa integrata per piani tavoli spessore max 30 mm, disponibile nei colori alluminio o nero, 289x120 mm con 2 mt. di cavo di alimentazione + 2 presa DE + 2 prese USB 5V/2, 4A + 2 prese RJ45.



**Optional (on demand)\*:**  
 Opzionali (su richiesta)\*:



\* dedicated quotation / quotazione dedicata

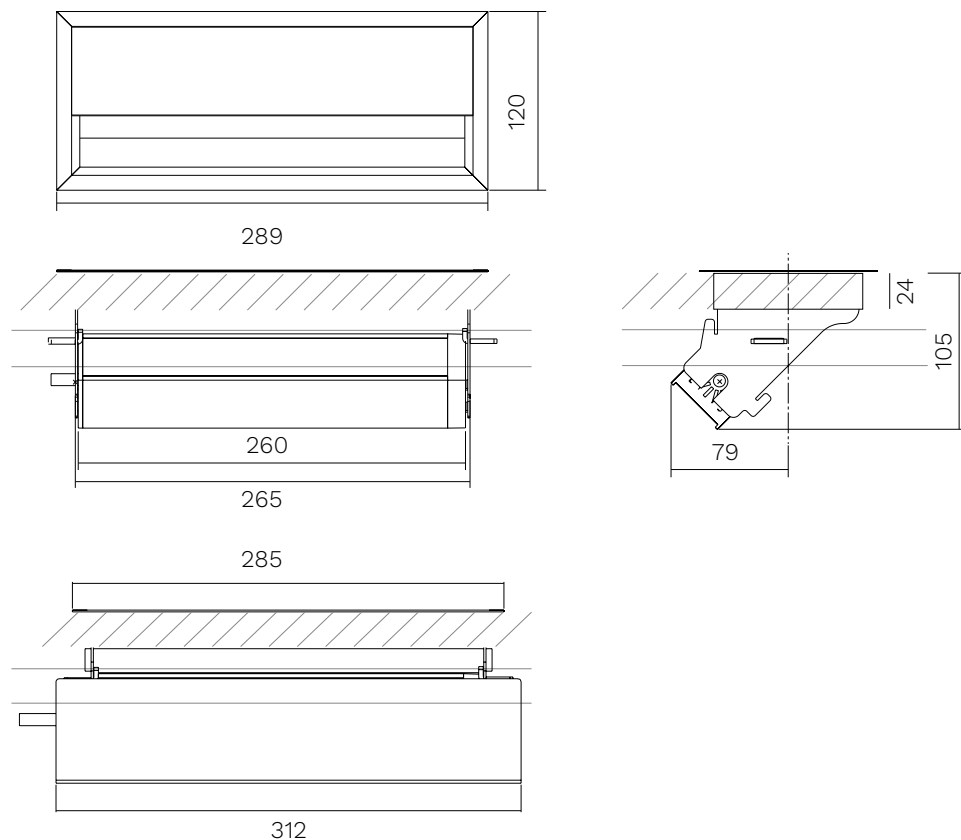

**Surface cut-out area**

Area di taglio della superficie



All measurements are indicated in mm  
 Tutte le misure sono indicate in mm

**COLOURS AVAILABLE / COLORI DISPONIBILI**

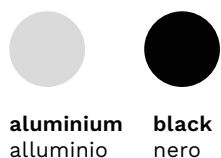



# TOP ACCESS WITH INTEGRATED MULTIFUNCTIONAL SOCKET

## PASSACAVI CON MULTIPRESA INTEGRATA

# mara®

PASD60

### DESCRIPTION / DESCRIZIONE

**en** Top access round with integrated multifunctional socket for table tops, available in white or black colours, diameter 60 mm with 1,5 mt. power cable + 1 DE + 1 USB 5V/2, 4A socket.

**it** Presa multifunzione rotonda per piani tavoli, disponibile nei colori bianco o nero, diametro 60 mm con 1,5 mt. di cavo di alimentazione + 1 presa DE + 1 presa USB 5V/2, 4A.



**Optional (on demand)\*:**  
Opzionali (su richiesta)\*:

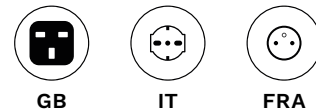

\* dedicated quotation / quotazione dedicata

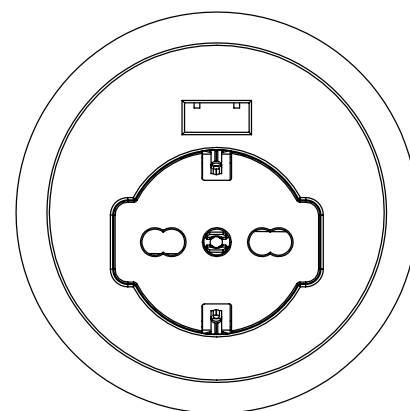
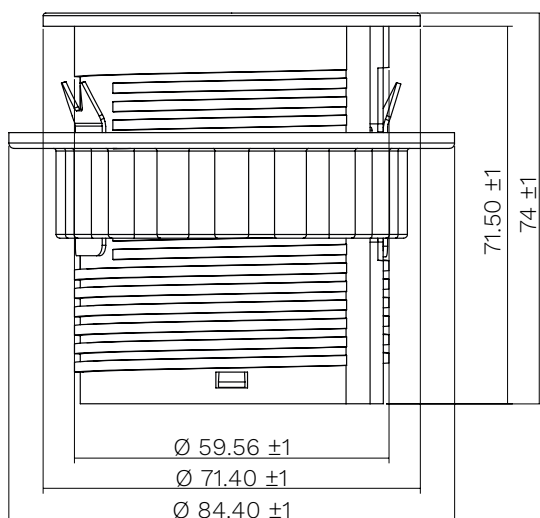

**Surface cut-out area**

Area di taglio della superficie

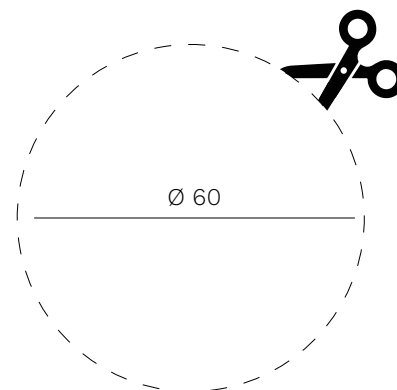

All measurements are indicated in mm  
Tutte le misure sono indicate in mm

### COLOURS AVAILABLE / COLORI DISPONIBILI



**white**  
bianco



**black**  
nero



REV022025

MARA SRL | Via Adua 11, 25050 Passirano (BS) Italy | T. +39 030 6857568 | marasrl.it

# CABLE MANAGEMENT WITH INTEGRATED MULTISOCKET PASSACAPO CON MULTIPRESA INTEGRATA

**mara**<sup>®</sup>

PASD80

## DESCRIPTION / DESCRIZIONE

**en** Top access round with integrated multifunctional socket for table tops, available in white or black colours, diameter 80 mm with 2 mt. power cable + 1 DE + 2 USB 5V/2, 4A socket + 1 RJ45 (interchangeable). The inside of the cover is equipped with a wireless charger (usable only when open).

**it** Presa multifunzione rotonda per piani tavoli, disponibile nei colori bianco o nero, diametro 80 mm con 2 mt. di cavo di alimentazione + 1 presa DE + 2 prese USB 5V/2, 4A + 1 presa RJ45 (intercambiabile). L'interno del coperchio è provvisto di caricatore wireless (utilizzabile solo quando aperto).



wireless recharge

RJ45

DE

USB

1

**Optional (on demand)\*:**  
Opzionali (su richiesta)\*:



HDMI



EXIT



GB



IT



FRA

\* dedicated quotation and minimum order  
\* quotazione dedicata e minimo d'ordine

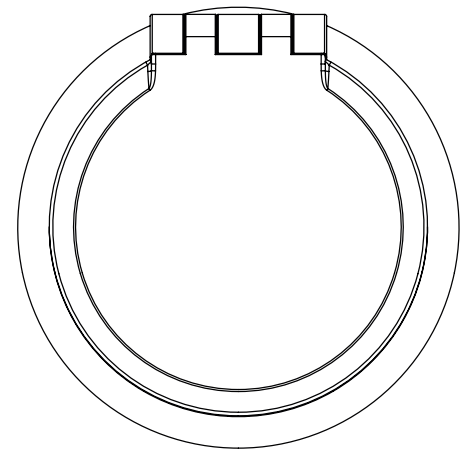
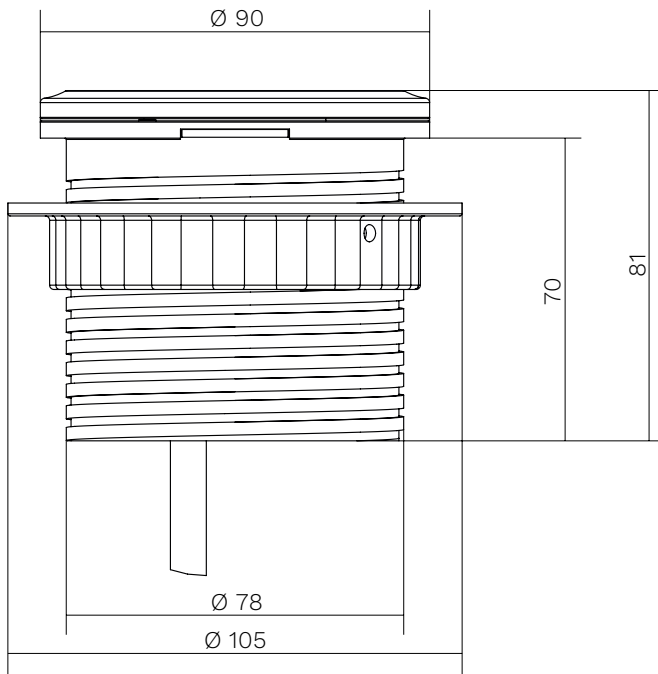

**Surface cut-out area**  
Area di taglio della superficie

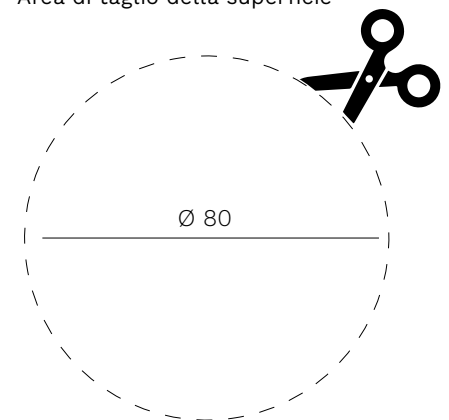

All measurements are indicated in mm  
Tutte le misure sono indicate in mm

## COLOURS AVAILABLE / COLORI DISPONIBILI



white  
bianco



black  
nero





**en** All the energy used in our company is 100% green and comes exclusively from renewable sources.

**it** Tutta l'energia utilizzata nella nostra azienda è 100% GREEN e proviene esclusivamente da fonti rinnovabili.

**en** As it is always seeking to improve its products, the company reserves the right to modify or upgrade the products without prior notice, at any time. Colors should be considered purely indicative. Mara's Collections are worldwide protected by the industrial property right and patents.

**it** Mara, sempre alla ricerca del miglioramento dei propri prodotti, si riserva la facoltà di apportare modifiche costruttive e funzionali in qualsiasi momento senza alcun preavviso. I colori dei materiali sono da ritenersi puramente indicativi. Tutte le collezioni Mara sono protette nel mondo dal diritto di proprietà industriale e da brevetti registrati.